



"We'll see you right"

# THE RIGHT WAY TO BUILD A DECK



## WHAT YOU'LL NEED:

### TOOLS

- ELECTRIC DRILL
- HAMMER
- HANDSAW OR ELECTRIC SAW
- RETRACTABLE TAPE MEASURE
- SET SQUARE
- ADJUSTABLE WRENCH
- SPADE
- SPIRIT LEVEL
- STRING LINE

### MATERIALS

- 6 - 125 X 125 MM H5 TREATED TIMBER PILES LENGTHS TO SUIT TERRAIN
- 1 - 3.0 M LENGTH EX 150 X 50 MM SG8 OR NO.1 FRAMING GRADE H3.2 TREATED STRINGER
- 2-3 BAGS (APPROX) HANDY CONCRETE MIX
- 10 - 3.0 M LENGTHS EX 100 X 50 MM SG8 OR NO.1 FRAMING GRADE H3.2 TREATED JOISTS
- 100 METRES, EX 100 X 25 MM OR 100 X 40 MM PROFILED DECKING
- 7 - 12 MM GALVANISED BOLTS (CHECK LENGTHS)
- 14 - 50 X 50 X 3 MM WASHERS (GALVANISED)
- 2 - 3.0 M LENGTHS EX 100 X 75 MM SG8 OR NO.1 FRAMING GRADE H3.2 TREATED BEARERS
- 75 X 12 X 150 MM LONG TIMBER PACKERS FOR WALL FIXINGS
- QUANTITY OF 100 X 4 MM GALV FLAT HEAD NAILS
- QUANTITY OF 60 MM OR 75 MM ANNULAR GROOVE GALVANISED FLAT HEAD NAILS
- 8 WIRE DOGS

## DISCLAIMER

Please Note: Whilst the advice and recommendations contained in this brochure have been produced with proper care, they are offered only with the object of assisting those interested in home improvement projects and ITM does not accept responsibility for the advice, recommendations, etc. contained herein.

If you have any queries please contact your local ITM store for further advice.

Note: A Building Consent will be required where the deck height exceeds 1.5 metres.



Produced in association with BRANZ.

CHECK OUT OUR OTHER GUIDES IN STORE OR ON THE WEBSITE WWW.ITM.CO.NZ



"We'll see you right"

## INTRODUCTION

A deck is a system of piles, bearers and joists supporting the timber decking. Piles must be treated to H5 level and all other timber must be treated H3.2.

Any exterior structure should be built using galvanised nails and fastenings. In coastal or geothermal areas, stainless steel fixings should be used. If in doubt, check with your council.

This plan is for a deck 3m wide, has 4 bays, extends from a house.

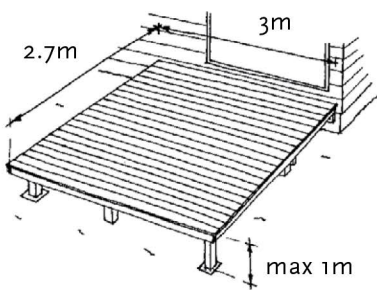

## PLANNING & BUILDING CONSENT

Before planning your deck, check with your council about any planning restrictions. Some councils require a consent for any deck (regardless of height) that is partly supported by a house.

Planning restrictions vary from area to area. The area of your deck may be limited due to its distance from boundaries, height restrictions etc. In addition to planning consent, you may need to get your neighbours' permission.

Any deck from which a person may fall more than 1.5 metres will require handrails and a building consent from your local authority.

Detailed plans showing the position of the deck and how it is to be constructed (including handrails, steps and bracing) will need to be prepared for the application for your building consent. Seek advice from a design professional if your deck is more than 1.5 metres out of the ground.

It is often a good idea to obtain a building consent (even if it's not required) to assure a future buyer that the deck was correctly built.

The deck featured in this brochure is less than 1.5 metres above ground and doesn't require a building consent, but it must comply with the building code.

It is suitable for a flat or gently sloping site and must be attached to the house at least 400 mm above ground level. It will comply with the provisions of the NZ Building Code, and will not require a building consent provided it is not possible to fall more than 1.5 metres from the deck onto the ground.

No handrail is required, but take care if installing structures such as planter boxes or seating which people might fall from.

The deck is 3m wide, extends from the house 2.7 m, and has 4 bays. You can change the area by adding or omitting bays. It's helpful to draw up a basic plan to work out joist and bearer spacing and lengths.

## STEP 1 SET OUT THE DECK

**A** Measure down from floor level at least 170 mm and draw a level line to mark where the top of the stringer (the timber member attached to the house) will go and check that fixings (75 mm below this line) will be securely set into the framing or foundation wall.

**B** Fix a 150 x 50 mm stringer (3m long) to this line with a minimum of three 12 mm bolts, 300 mm from each end and in the centre. Use a 50 x 50 x 3 mm washer where the bolt bears on the timber.

**C** Pack stringers off wall cladding with 75 x 12 x 150 mm long timber packers at each bolt position. This will allow drainage between stringer and wall cladding.

**D** Construct profiles (diagram 1) about 900 mm outside the outline of the deck ensuring that the horizontal profile rails are the same level as the top of the stringer.

**E** Using string lines set out the perimeter of the deck, checking that the diagonal dimensions are equal, to ensure the deck is square.

**F** Partly hammer a nail into the top of the profile to mark these lines and another 200 mm inside these lines to mark the outside edge of the piles.

**THE BASIC SET-OUT OF YOUR DECK IS NOW DONE!**

### TIP

A week or two before starting your deck, it is a good idea to weed spray the area to be covered to keep weeds down after the deck is completed.

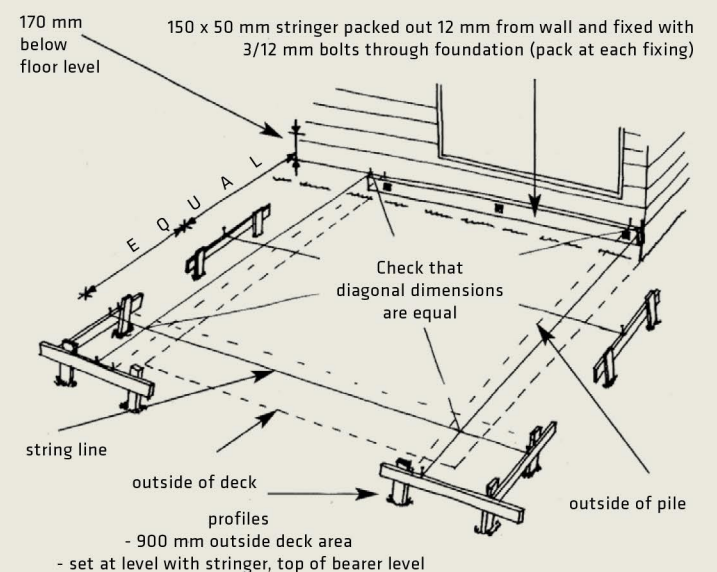

DIAGRAM 1



STEP 2

## DIGGING THE PILE HOLES

Using the string lines set to the inside nails on the profiles, mark the positions of each 125 x 125 mm square pile on the ground. Position piles at each corner with the outside face in line with the string line. The intermediate piles will be centred below the string line and in the centre of the deck (diagram 2). Mark the position of the piles and the size of the hole with spray paint.

For the two corner piles, dig a 350 x 350 mm square hole 900 mm deep (below topsoil level). This will form the foundation for an anchor pile which will brace your deck. Dig 250 x 250 mm holes at least 250 mm deep for the other piles. Make sure you dig through the topsoil to solid ground. The spacing between piles should be 1350 mm (centre to centre). The poles can also be extended up to support a handrail or overhead pergola.

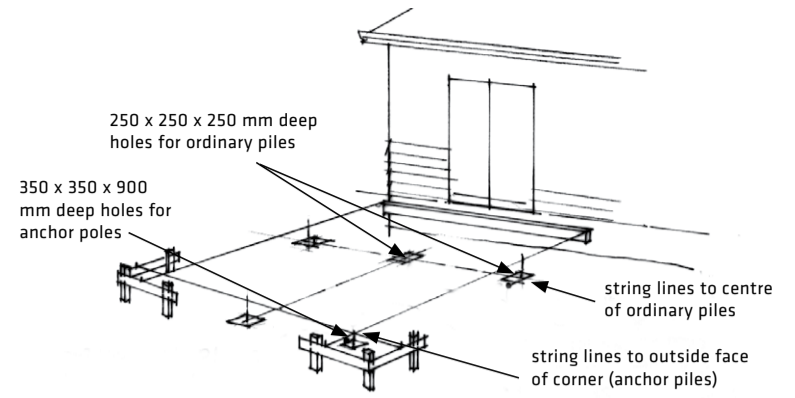

STEP 3

## PLACING PILES

### (A) CORNER OR ANCHOR PILES

The length of the corner piles will be 100 mm shorter than the distance from the string line to the bottom of the 900 mm deep hole. This is to provide clearance above the pile when the joists are fitted. If the pile needs to be cut, ensure that the cut end is placed at the top. Partly hammer a nail through the timber batten to the pile to hold the end of the pile 100 mm above the bottom of the hole (diagram 3) to allow for at least 100 mm of concrete under the pile.

Align the outside edges of the pile with the string lines and if necessary provide temporary braces to the pile to secure it in position while concrete is poured in the hole. Place 150 mm of concrete in the bottom of the hole and rod it with a piece of 50 x 25 timber to ensure that concrete is forced completely under and around the pile.

Check the height and that the pile is square with the string line. Use a spirit level to check that it is plumb. Make adjustments if necessary and then proceed to add further concrete, about 150 mm at a time (prodding the concrete as you go) until the hole is full. Check the position of the pile again and then leave for the recommended cure time (see your concrete packet for details).

### (B) INTERMEDIATE (ORDINARY) PILES

Intermediate piles will be 194 mm shorter than the distance from the string line to the bottom of the hole. This is to allow 100 mm of concrete under the pile and a 100 x 75 mm bearer (finished width of 94 mm) to be fitted on the pile. Pour 100 mm of concrete in the hole and place the pile on concrete (uncut end down). Work the pile gently into the concrete and check the finished height by placing a 94 mm thick timber off-cut on the pile. The off-cut should finish at the string line height and the pile should be centred under the string line. When the concrete has set, the remainder of the hole around the pile can be filled with earth or concrete.

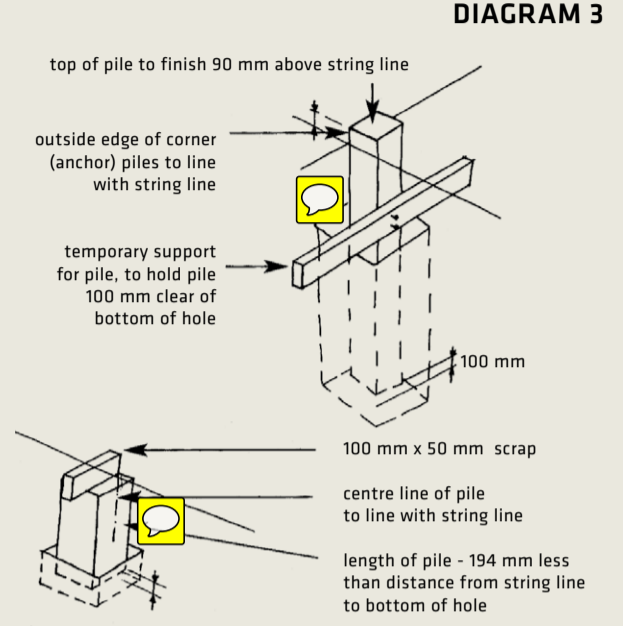

DIAGRAM 3

STEP 4

## PLACING THE BEARERS

The 100 x 75 mm bearer should be bolted to the corner piles on the front edge of the deck using a 12 mm bolt with a 50 x 50 x 3 mm washer under the head and nut. The top surface of the bearer should line up with the string line and the bearer should sit on the centre pile. Fix to the centre pile with a 100 x 4 mm nail and a wire dog each side of the pile (diagram 4). Place the centre bearer on the piles and fix with nails and wire dogs.

Check the level of the bearer before fixing and if necessary, pack with malthoid, or notch over the pile. If the piles have been set accurately, this adjustment should be minimal. Once fixed, the bearers should be level across their length and with one another. Trim the ends of the bearers to finish in line with the outside string line (diagram 2).

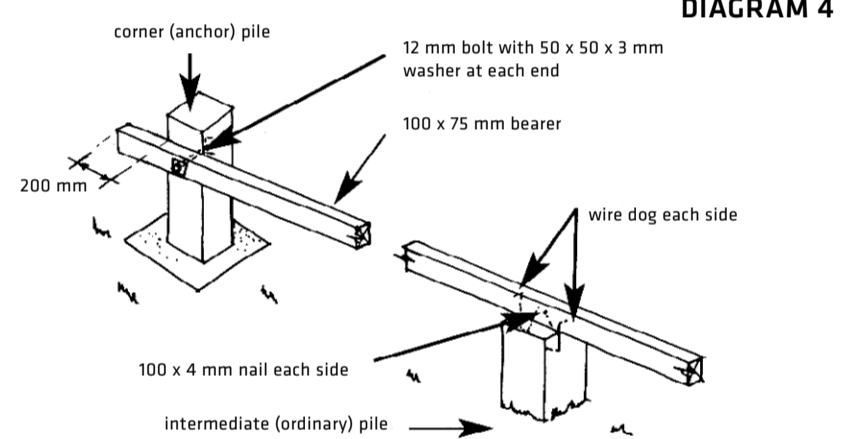

DIAGRAM 4

STEP 5

## PLACING THE JOISTS

Place the joists against the inside face of the corner piles and bolt them with 12 mm bolts and 50 x 50 x 3 mm washers (diagram 5). At the middle bearer and stringer, fix with two 100 x 4 mm nails. Place the outside joists in line with the ends of the bearers and then place remainder of the intermediate joists in position, evenly spaced at a maximum of 450 mm centres. Fix bearers with two 100 x 4 mm nails.

Trim the front edge of the joists 50 mm inside the line of the outside string line (diagram 1) and fix a 100 x 50 mm boundary joist to the ends of the joists with two 100 x 4 mm nails nailed into the ends of each joist.

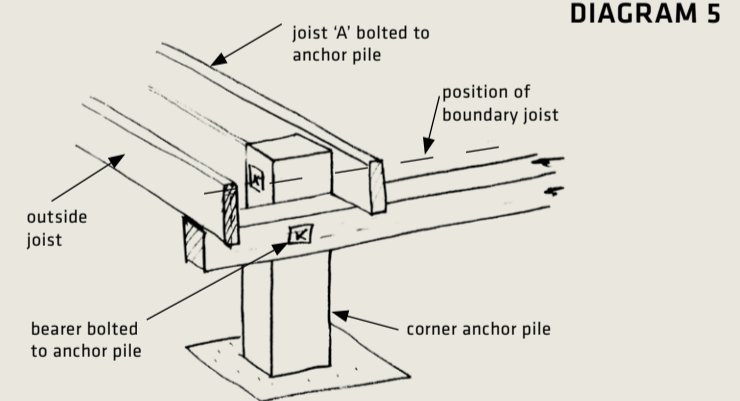

DIAGRAM 5

STEP 6

## PLACING THE DECKING

Lay the first piece of decking with a 12 mm gap to the house to allow drainage. Tack in place, check that it is straight, then nail the board with two 60 mm galvanised flat head nails at each joist. Overhang the ends of the boards approximately 100 mm. Proceed with the next boards, using a 75 mm nail to set the space between the boards. For 19 mm decking, use 60 mm galvanised nails. For 40 mm decking, use 75 mm galvanised nails.

Any joints should be positioned centrally over a joist with both boards carefully lined up and nailed. It may be necessary to drill for the nails on the end of the boards to reduce the chance of the wood splitting. Joints in boards should be staggered, i.e. they should not occur on the same joist in adjacent boards. The number of joints should be minimised (diagram 6).

Check every fifth or sixth board to ensure they are still parallel with the house foundation and that the outside ends of the boards are in line with a consistent overhang to the outside joist. The last board should overhang the boundary joist about 10 mm.

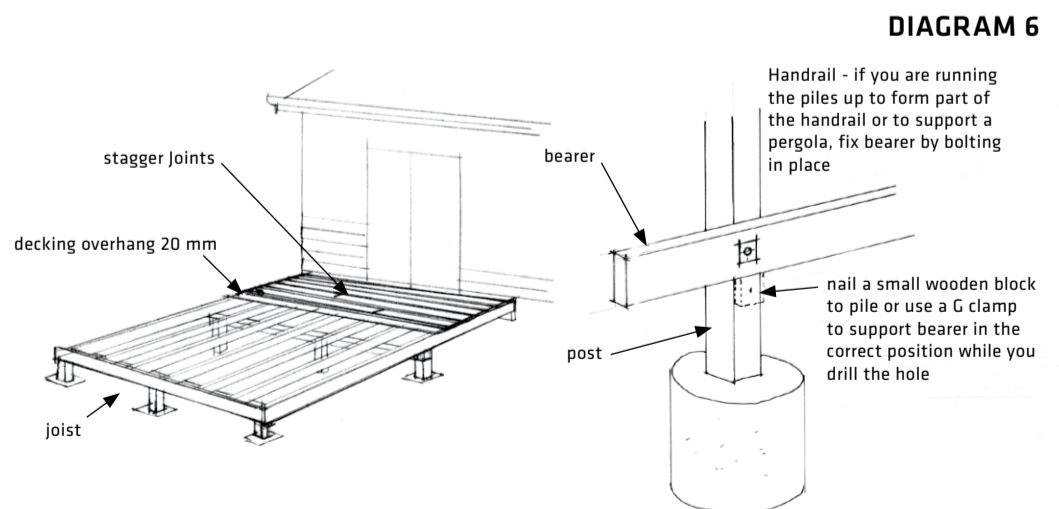

DIAGRAM 6

STEP 7

## PAINT OR STAIN?

It is not necessary to paint or stain your deck, but if you wish to have a finish, make sure you apply it to the joists and bearers prior to fixing the decking. With the decking boards, make sure the finish is applied on the top and edges before fixing. The surface of the decking should be profiled to provide a slip resistant finish. This surface will require cleaning once a year to remove mould and to ensure your deck remains safe to walk on.

